

# Digital Timer *Eliro*<sup>®</sup>

- Compact 17.5 mm Wide
- Multi Function: (8 or 18) Non Signal & Signal based functions
- Multi-Voltage: 24 - 240 VAC/DC
- Wide Timing Range: 0.1s to 999 Hr
- 3 Digit LCD for Preset time and Run time
- Option to select Up/Down counting
- Tamper proof with key lock feature





## Ordering Information

Cat. No.	Description
V0DDTS	24 - 240 VAC/DC, Multi Function Digital Timer - Eliro (8 Functions), 1 C/O
V0DDTD	24 - 240 VAC/DC, Multi Function Digital Timer - Eliro (8 Functions), 2 NO
V0DDTS1	24 - 240 VAC/DC, Multi Function Digital Timer - Eliro (18 Functions), 1 C/O
V0DDTD1	24 - 240 VAC/DC, Multi Function Digital Timer - Eliro (18 Functions), 2 NO

# Digital Timer *Eliso*<sup>®</sup>



Cat. No.	V0DDTS	V0DDTD	V0DDTS1	V0DDTD1	
<b>Parameters</b>					
Timer Description	Multi Function Digital Timer				
Functions	1) ON Delay 2) Cyclic OFF/ON 3) Cyclic ON/OFF 4) Signal ON/OFF 5) Signal OFF Delay 6) Interval 7) Signal OFF/ON 8) One Shot Output		1) ON Delay 2) Cyclic OFF/ON 3) Cyclic ON/OFF 4) Impulse on Energizing 5) Accumulative Delay on Signal 6) Accumulative Delay on Inverted Signal 7) Accumulative Impulse on Signal 8) Signal ON Delay 9) Inverted Signal ON Delay 10) Signal OFF Delay 11) Impulse ON/OFF 12) Signal OFF/ON 13) Leading Edge Impulse 1 14) Leading Edge Impulse 2 15) Trailing Edge Impulse 1 16) Trailing Edge Impulse 2 17) Delayed Impulse 18) Inverted Signal ON Delay		
Supply Voltage (±)	24 - 240 VAC/DC				
Supply Variation	-15% to +10% (of ±)				
Frequency	50/60 Hz				
Power Consumption (Max.)	0.5 VA (@ 24/48 VAC), 4 VA (@ 110 to 265 VAC/DC)				
Timing Range	0.1s to 999h				
Reset Time	200 ms (Max.)				
Repeat Accuracy	± 0.5%				
Output	Relay Output	1 C/O	2 NO	1 C/O	2 NO
	Contact Rating	8A @ 240 VAC / 24 VDC (Resistive)			
	Electrical Life	1x10 <sup>5</sup>			
	Mechanical Life	2x10 <sup>7</sup>			
Utilization Category	AC - 15	Rated Voltage (Ue): 125/240 V, Rated Current (Ie): 3/1.5 A			
	DC - 13	Rated Voltage (Ue): 125/250 V, Rated Current (Ie): 2/0.22/0.1 A			
Operating Temperature	-10° C to +55° C				
Storage Temperature	-20° C to +65° C				
Humidity (Non Condensing)	95% (Rh)				
LED Indication	Red LED → Relay ON				
Enclosure	Flame Retardant UL94-V0				
Dimension (W x H x D) (in mm)	18 X 85 X 76				
Weight (unpacked) Approx.	85 g				
Mounting	DIN Rail				
Certification	  				
Degree of Protection	IP 20 for Terminals, IP 30 for Enclosure				

## EMI / EMC

Harmonic Current Emissions	IEC 61000-3-2
ESD	IEC 61000-4-2
Radiated Susceptibility	IEC 61000-4-3
Electrical Fast Transients	IEC 61000-4-4
Surges	IEC 61000-4-5
Conducted Susceptibility	IEC 61000-4-6
Voltage Dips & Interruptions (AC)	IEC 61000-4-11
Voltage Dips & Interruptions (DC)	IEC 61000-4-29
Conducted Emission	CISPR 14-1
Radiated Emission	CISPR 14-1

## Environmental

Cold Heat	IEC 60068-2-1
Dry Heat	IEC 60068-2-2
Vibration	IEC 60068-2-6
Repetitive Shock	IEC 60068-2-27
Non-Repetitive Shock	IEC 60068-2-27

# Digital Timer *Eliso*<sup>®</sup>



## FUNCTIONAL DIAGRAMS FOR V0DDTS & V0DDTD

⊕ : Supply Voltage, S: Input Signal, R: Relay Output  
 T: Preset Time, TON: Preset ON Time, TOFF: Preset OFF Time

### ON DELAY (A)

On application of supply voltage, the preset time duration (T) starts. On completion of the preset time, the output is switched ON and remains ON till the supply voltage is present.



### CYCLIC OFF/ON {OFF Start, (Sym, Asym)} (b)

On application of supply voltage, the output is initially switched OFF for the preset 'OFF' time duration (TOFF) after which it is switched ON for the preset 'ON' time duration (TON). This cycle repeats and continues till the supply is present.



### CYCLIC ON/OFF {ON Start, (Sym, Asym)} (C)

On application of supply voltage, the output is initially switched ON for the preset 'ON' time duration (TON) after which it is switched OFF for the preset 'OFF' time duration (TOFF). This cycle repeats and continues till the supply is present.

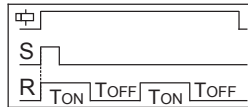

### SIGNAL ON/OFF (d)

The output relay is turned ON for Preset Time (T) whenever the Signal(S) is applied or removed.

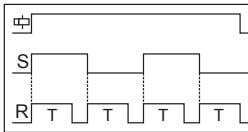

### SIGNAL OFF DELAY (E)

On application of supply voltage and input signal, the output is switched ON. When the signal is removed the preset time duration commences & the output is switched OFF at the end of the time duration.

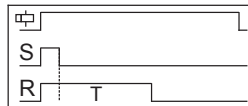

### INTERVAL(F)

When supply power is applied to the timer and on application of input signal the output is immediately switched ON. The output remains ON for the preset time duration (T) after which it is switched OFF.

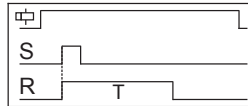

### SIGNAL OFF / ON (G)

When Signal (S) is applied or removed, the relay changes its state after Timer Duration (T)

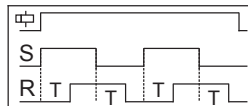

### ONE SHOT OUTPUT (H)

When Signal (S) is applied, the Timer Duration (T) starts. At the end of Timer duration (T), the relay gets energized for approximately 1 sec.(Refer Note : 2)

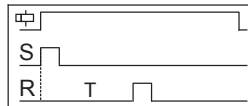

- Note:
1. For Power-On operation, connect the terminal B1 to A1 permanently.
  2. If the Signal (S) changes during the Timer Duration (T), it does not change the output relay but re-triggering takes places and the Timer Duration is extended.

# Digital Timer *Eliro*<sup>®</sup>



## FUNCTIONAL DIAGRAMS FOR V0DDTS1 & V0DDTD1

⏻: Supply Voltage, S: Input Signal, R: Relay Output  
 T: Preset Time, TON: Preset ON Time, TOFF: Preset OFF Time

### ON DELAY [0]

On application of supply voltage, the preset time duration (T) starts. On completion of the preset time, the output is switched ON and remains ON till the supply voltage is present.

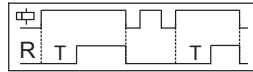

### CYCLIC OFF/ON {OFF Start, (Sym, Asym)} [1]

On application of supply voltage, the output is initially switched OFF for the preset 'OFF' time duration (TOFF) after which it is switched ON for the preset 'ON' time duration (TON). This cycle repeats and continues till the supply is present.



### CYCLIC ON/OFF {ON start, (Sym, Asym)} [2]

On application of supply voltage, the output is initially switched ON for the preset 'ON' time duration (TON) after which it is switched OFF for the preset 'OFF' time duration (TOFF). This cycle repeats and continues till the supply is present.



### IMPULSE ON ENERGIZING [3]

On application of supply voltage, the output is instantly switched ON for the preset time duration (T) after which it is switched OFF.

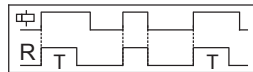

### ACCUMULATIVE DELAY ON SIGNAL [4]

On application of supply voltage, the preset timing duration commences. When input signal is applied, the timing pauses and resumes only when the input signal is removed. The output is switched ON at the end of the preset time duration (T).

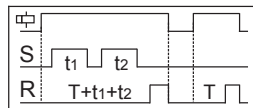

### ACCUMULATIVE DELAY ON INVERTED SIGNAL [5]

On application of supply voltage and input signal, the preset timing duration commences. When the signal is removed the timing pauses and resumes when the signal is applied. The output is switched ON at the end of the preset time duration (T).

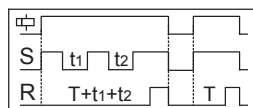

### ACCUMULATIVE IMPULSE ON SIGNAL [6]

On application of supply voltage the output is switched ON & the preset timing duration commences. When the signal is applied the timing pauses and resumes when the signal is removed. The output is switched OFF at the end of the preset time duration (T).

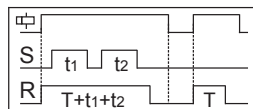

### SIGNAL ON DELAY [7]

On application of input signal, the preset time duration (T) starts. On completion of the preset time, the output is switched ON and remains ON till the input signal is present.

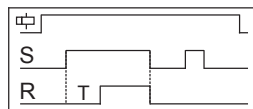

### INVERTED SIGNAL ON DELAY [8]

On application of supply voltage, the preset time duration (T) starts. When input signal is applied, the timing pauses & resumes only when the signal is removed. On completion of the preset time, the output is switched ON.

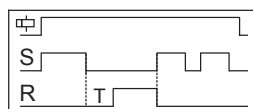

### SIGNAL OFF DELAY [9]

On application of supply voltage and input signal, the output is switched ON. When the signal is removed the preset time duration commences & the output is switched OFF at the end of the time duration.

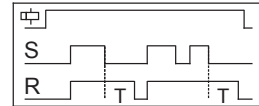

### IMPULSE ON/OFF [A]

On application or removal of input signal, the output is switched ON & the preset time duration (T) starts. On completion of the time duration the output is switched OFF. When timing commences, changing the state of the input signal resets the time.

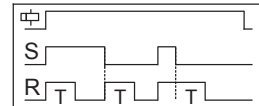

### SIGNAL OFF/ON [b]

On application of input signal, the preset delay time period (T) starts. On completion of the preset time, the output is switched ON. On removal of input signal, the preset time period starts again and the output is switched ON when the preset time duration is complete.

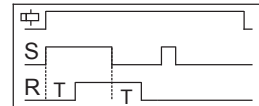

### LEADING EDGE IMPULSE1 [C]

On application of input signal the output is immediately switched ON. The output remains ON for the preset time duration (T) after which it is switched OFF. If the input signal is removed during the preset time, the output remains unaffected.

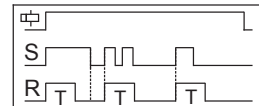

### LEADING EDGE IMPULSE2 [d]

On application of input signal the output is immediately switched ON. The output remains ON for the preset time duration (T) after which it is switched OFF. If the input signal is removed during the preset time, the output is immediately switched OFF.

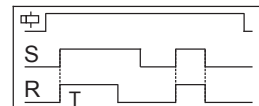

### TRAILING EDGE IMPULSE1 [E]

When the input signal to the timer is removed, the output is immediately switched ON for the preset time duration (T) after which it is switched OFF. If the input signal is applied during the preset time, the output is immediately switched OFF.

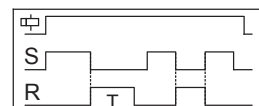

### TRAILING EDGE IMPULSE2 [F]

When the input signal to the timer is removed, the output is immediately switched ON for the preset time duration (T) after which it is switched OFF. If the input signal is applied during the preset time, the output remains unaffected.

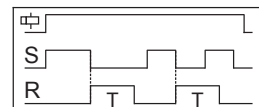

### DELAYED IMPULSE [G]

On application of input signal, the preset 'OFF' time duration (TOFF) starts. The output is switched ON at the end of the preset 'OFF' time duration & the preset 'ON' time duration commences irrespective of signal level and remains ON till the completion of 'TON'.

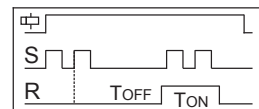

### INVERTED SIGNAL ON DELAY-TYPE 2 [H]

Timing starts only upon signal 'S' transition high to low. During timing or after completion of Time (i.e. relay on), any signal transition is ignored. To reset the timer supply has to be interrupted.

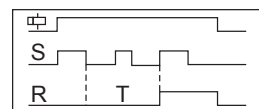

# Programmable Digital Timer *Eliro*<sup>®</sup>

- Digital 7-Segment display Supply Voltage range of 110-240 VAC
- Input Signal Sensing range of 85-265 VAC/100-265 VDC & 20-60 VAC/DC
- Inbuilt library of 33 functions covering majority applications
- Easy steps to program customized functions
- Suitable for Panel and Base/DIN mounting
- Two separate Channel outputs with selectable Timer modes
- Wide timing range - 0.1 Sec. to 999 Days
- Tamper proof with key lock feature
- Provision to edit Preset time during Run time
- Provision to save two independent functional Profiles (P1 & P2)





## Ordering Information

Cat. No.	Description
V7DFTS3	110 - 240 VAC, Multi Function Digital Timer - Eliro (33 Functions), 2 C/O
V7DDSS3	110 - 240 VAC, Multi Function Digital Timer - Eliro (33 Functions), 2 C/O, 11 Pin Universal socket

# Programmable Digital Timer *Eliso*<sup>®</sup>



Cat. No.	V7DFTS3	V7DDSS3
<b>Parameters</b>	<b>Programmable Multi Function Digital Timer</b>	
Timer Description	Programmable Multi Function Digital Timer	
Default Functions	1) On delay 2) On delay constant supply type 2 3) On delay constant supply type 3 4) On delay (control switch resettable) 5) Signal on delay 6) Inverted signal on delay 7) Inverted signal on delay type 2 8) Signal off delay 9) Off delay const. supply type 2 10) Cyclic on/off 11) Cyclic off/on 12) Asymmetric cycle pulse start 13) Asymmetric recycler pulse start type 2 14) Signal on off delay 15) Signal on off delay type 2 16) Signal off/on (new)	17) Impulse on energizing 18) Impulse on/off 19) Accumulative delay on signal 20) Accumulative delay on inverted signal 21) Accumulative impulse on signal 22) Leading edge impulse 23) Leading edge impulse 2 24) Trailing edge impulse 25) Trailing edge impulse 2 26) Delayed impulse 27) Delayed impulse type 2 28) Delayed pulse (constant supply) 29) Delayed pulse (remote trig.) 30) Delayed pulse (const. supply type 1) 31) On pulse (control switch resettable) 32) On pulse (supply reset)mode 33) Leading edge bi-stable or step relay
Supply Voltage (ϕ)	110 - 240 VAC	
Supply Variation	-20% to +10% (of ϕ)	
Frequency	47-63 Hz	
Power Consumption (Max.)	9 VA	
Timing Range	0.1s to 999 days	
Reset Time/Initiate Time	200 ms (Max.) / 100 ms (Max.)	
Input Signals/Signal Isolation	High Range: 85-265V AC/ 100-265V DC, Low Range: 24-60V AC/DC / 2 KV	
Signal Sensing Time/ Wait Period	50ms. (max.) / 100ms @ Power On & for signal based modes only.	
Timing Accuracy	± 0.01%	
Output	Relay Output	2 C/O
	Contact Rating	5A for NO & 3A for NC @ 250VAC/30VDC (Resistive.)
	Electrical Life	1x10 <sup>5</sup>
	Mechanical Life	5x10 <sup>6</sup>
Utilization Category	AC - 15	250V AC/2A, Cos ϕ = 0.6, 85°C, 100000 Operations.
	DC - 13	Ue rated voltage V – 24; Ie rated current A – 2.0.
Operating Temperature	-5° C to +55° C	
Storage Temperature	-10° C to +60° C	
Humidity (Non Condensing)	95% (Rh)	
LED Indication	SV (Red) - Set Value; P1/P2 (Red) -P1 Running; Up/Down (Red)-Up Counting; SG (Green)- Signal Present;OP1 (Red)-Relay OP1 ON;OP2 (Red)-Relay OP2 ON;	
Enclosure	IP 30 for Housing & front Facial and IP 20 for Terminals	
Dimension (W x H x D) (in mm)	48 X 48 X 92.5	
Weight (unpacked)	160 g	
Mounting	Panel / Flush Mountable	Base / DIN Rail with 11 Pin Universal socket
Certification	  	
Degree of Protection	IP 20 for Terminals, IP 30 for Enclosure	

## EMI / EMC

Harmonic Current Emissions	IEC 61000-3-2
ESD	IEC 61000-4-2
Radiated Susceptibility	IEC 61000-4-3
Electrical Fast Transients	IEC 61000-4-4
Surges	IEC 61000-4-5
Conducted Susceptibility	IEC 61000-4-6
Voltage Dips & Interruptions (AC)	IEC 61000-4-11
Voltage Dips & Interruptions (DC)	IEC 61000-4-29
Conducted Emission	CISPR 14-1
Radiated Emission	CISPR 14-1

## Environmental

Cold Heat	IEC 60068-2-1
Dry Heat	IEC 60068-2-2
Vibration	IEC 60068-2-6
Repetitive Shock	IEC 60068-2-27
Non-Repetitive Shock	IEC 60068-2-27

# Programmable Digital Timer *Eliso*<sup>®</sup>



## FUNCTIONAL DIAGRAMS

☐ : Supply Voltage, S: Input Signal, R: Relay Output

T: Preset Time, TON: Preset ON Time, TOFF: Preset OFF Time, T-a: Timing Break Before completion

### ON DELAY [00]

On application of supply voltage, the preset time duration (T) starts. On completion of the preset time, the output is switched ON and remains ON till the supply voltage is present.

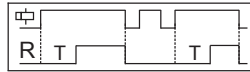

### SIGNAL OFF DELAY [07]

On application of supply voltage and input signal, the output is switched ON. When the signal is removed the preset time duration commences & the output is switched OFF at the end of the time duration.

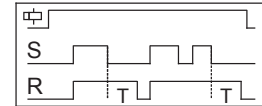

### ON DELAY CONSTANT SUPPLY TYPE 2 [01]

Timing will commence when the supply is present and input signal is not applied. After the time period has elapsed, output is switched ON. If signal is applied then the timing period stops. Timing will restart only when signal is removed. Therefore there are two methods this timer can be controlled, either by application or removal of signal input and with the interruption of the supply voltage to the timer with signal removal.

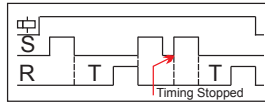

### OFF DELAY CONST. SUPPLY TYPE 2 [08]

A permanent supply is required. When the input signal is applied the output is switched ON immediately. When input signal is removed the timing period starts. After the time period has elapsed output is switched OFF. Once the timing period has started further actions of input signal will have no effect. However once the timing cycle has been completed the process may be started again applying input signal. While the timer is executing the only way to reset the timer is to interrupt the supply.

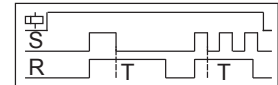

### ON DELAY CONSTANT SUPPLY TYPE 3 [02]

A permanent supply is required. The timing period starts when the signal is applied and will continue irrespective of any further changes to signal input. After the time period has elapsed output is switched ON. Signal change has no effect during timing period. To reset the timer, signal must be removed and then applied.

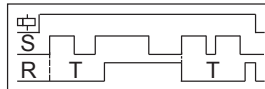

### CYCLIC ON/OFF {ON start, (Sym, Asym)} [09]

On application of supply voltage, the output is initially switched ON for the preset 'ON' time duration (TON) after which it is switched OFF for the preset 'OFF' time duration (TOFF). This cycle repeats and continues till the supply is present.



### ON DELAY (CONTROL SWITCH RESETTABLE) [03]

When the supply is connected and signal is applied, the timing function starts. If signal is removed and applied during the preset timing then timing is restarted and output stays OFF. After preset time has elapsed the output is ON.

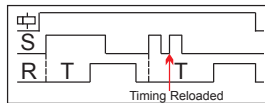

### CYCLIC OFF/ON {OFF Start, (Sym, Asym)} [10]

On application of supply voltage, the output is initially switched OFF for the preset 'OFF' time duration (TOFF) after which it is switched ON for the preset 'ON' time duration (TON). This cycle repeats and continues till the supply is present.



### SIGNAL ON DELAY [04]

On application of input signal, the preset time duration (T) starts. On completion of the preset time, the output is switched ON and remains ON till the input signal is present.

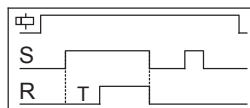

### ASYMMETRIC CYCLE PULSE START [11]

A permanent supply is required. The timer function is triggered by the input signal. When input signal applied the output is switched ON while the first preset time period (TON) elapses. Once this time period (TON) has elapsed output is switched OFF for the second preset time (TOFF) period. Once this second time period (TOFF) had elapsed then output switched ON and the cycle will start from the beginning again. If input signal is removed during timing (TON or TOFF) the cycle will stop and output is switched OFF, cycle will start with output ON state when the input signal applied again.

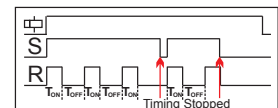

### INVERTED SIGNAL ON DELAY [05]

On application of supply voltage, the preset time duration (T) starts. When input signal is applied, the timing pauses & resumes only when the signal is removed. On completion of the preset time, the output is switched ON.

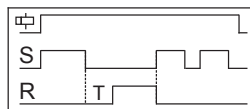

### ASYMMETRIC RECYCLER PULSE START TYPE 2 [12]

A permanent supply is required. The timer function is triggered by input signal. When input signal is applied the output is switched OFF while the first preset time period (TOFF) elapses. Once this time period has elapsed output is switched ON for the second preset time period (TON). Once this second time period (TON) had elapsed then output is switched OFF and the cycle will start from the beginning again. If input signal is removed during timing (TON or TOFF) the cycle will stop and output is switched OFF, cycle will start with output OFF state when the input signal applied again.

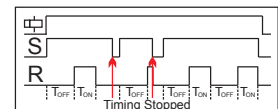

### INVERTED SIGNAL ON DELAY-TYPE 2 [06]

Timing starts only upon signal 'S' transition high to low. During timing or after completion of Time (i.e. relay on), any signal transition is ignored. To reset the timer supply has to be interrupted.

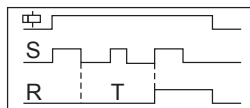

### SIGNAL ON OFF DELAY [13]

On application of signal the preset time (T) starts. After this preset time has elapsed, output is switched ON. During this timing, if signal is removed then output is switched ON immediately and OFF delay is started. Once this time period has elapsed the output is switched OFF. During this OFF delay if signal is reapplied the output switched OFF immediately and ON Delay restarted.

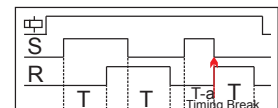

# Programmable Digital Timer *Eliso*<sup>®</sup>



## FUNCTIONAL DIAGRAMS

### SIGNAL ON OFF DELAY TYPE 2 [14]

On application of signal the preset time (T) starts. After this preset time has elapsed, output is switched ON. During this timing, if signal is removed then output is switched ON immediately and preset timing is restarted. Removing the signal during this timing suspends timing but does not reset the time sequence. Timing will resume immediately when signal is applied. Therefore, total time taken before the delayed contact changes state is the preset time plus any time that the signal is removed. Once this time period has elapsed the output is switched OFF.

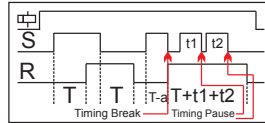

### SIGNAL OFF/ON [15]

On application of input signal, the preset delay time period (T) starts. During this timing if signal is removed then timing is stopped and timing will be restarted when signal applied again. After this time period has elapsed output is switched ON. On removal of input signal, the preset time period starts again & the output is switched OFF when the preset time duration is complete. Output stays OFF until supply voltage has been interrupted.

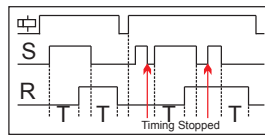

### IMPULSE ON ENERGIZING [16]

On application of supply voltage, the output is instantly switched ON for the preset time duration (T) after which it is switched OFF.

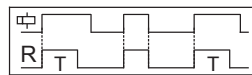

### IMPULSE ON/OFF [17]

On application or removal of input signal, the output is switched ON & the preset time duration (T) starts. On completion of the time duration the output is switched OFF. When timing commences, changing the state of the input signal resets the time.

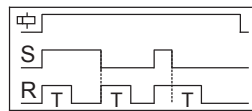

### ACCUMULATIVE DELAY ON SIGNAL [18]

On application of supply voltage, the preset timing duration commences. When input signal is applied, the timing pauses and resumes only when the input signal is removed. The output is switched ON at the end of the preset time duration (T).

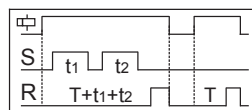

### ACCUMULATIVE DELAY ON INVERTED SIGNAL [19]

On application of supply voltage and input signal, the preset timing duration commences. When the signal is removed the timing pauses and resumes when the signal is applied. The output is switched ON at the end of the preset time duration (T).

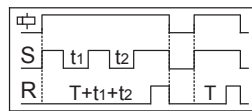

### ACCUMULATIVE IMPULSE ON SIGNAL [20]

On application of supply voltage the output is switched ON & the preset timing duration commences. When the signal is applied the timing pauses and resumes when the signal is removed. The output is switched OFF at the end of the preset time duration (T).

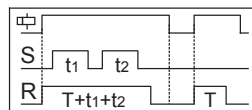

☐: Supply Voltage, S: Input Signal, R: Relay Output

T: Preset Time, TON: Preset ON Time, TOFF: Preset OFF Time

### LEADING EDGE IMPULSE1 [21]

On application of input signal the output is immediately switched ON. The output remains ON for the preset time duration (T) after which it is switched OFF. If the input signal is removed during the preset time, the output remains unaffected.

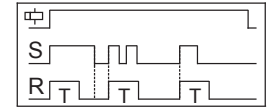

### LEADING EDGE IMPULSE2 [22]

On application of input signal the output is immediately switched ON. The output remains ON for the preset time duration (T) after which it is switched OFF. If the input signal is removed during the preset time, the output is immediately switched OFF.

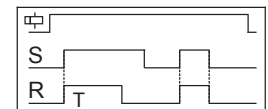

### TRAILING EDGE IMPULSE1 [23]

When the input signal to the timer is removed, the output is immediately switched ON for the preset time duration (T) after which it is switched OFF. If the input signal is applied during the preset time, the output is immediately switched OFF.

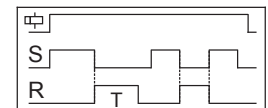

### TRAILING EDGE IMPULSE2 [24]

When the input signal to the timer is removed, the output is immediately switched ON for the preset time duration (T) after which it is switched OFF. If the input signal is applied during the preset time, the output remains unaffected.

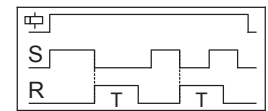

### DELAYED IMPULSE [25]

On application of input signal, the preset 'OFF' time duration (TOFF) starts. The output is switched ON at the end of the preset 'OFF' time duration & the preset 'ON' time duration commences irrespective of signal level and remains ON till the completion of 'Ton'.

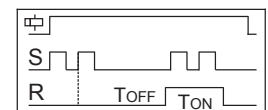

### DELAYED IMPULSE TYPE 2 [26]

A permanent supply is required. When signal is applied the output will remain OFF while the first preset time period (TOFF) elapses. Once this time period has elapsed the output is switched ON for the second preset time period (TON). Once this second time period (TON) had elapsed then output is switched OFF and cycle stops. Output stays OFF until supply voltage has been interrupted. During timing period (TON or TOFF) if signal is removed then output is switched OFF and the cycle stops, cycle will start with output OFF state when the input signal applied again.

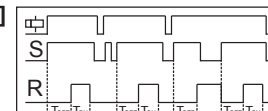

### DELAYED PULSE (CONSTANT SUPPLY) POWER BASED [27]

The timing period (TOFF) starts when the supply is applied to the timer. After the preset has elapsed output is switched ON for the preset pulse (TON) duration. To reset the timer the supply has to be interrupted. If this interruption occurs during the pulsed output (TON) then the output is switched OFF and the timer will reset.

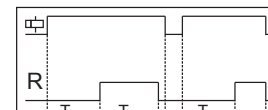



# Programmable Digital Timer *Eliso*<sup>®</sup>



## FUNCTIONAL DIAGRAMS

⏻: Supply Voltage, S: Input Signal, R: Relay Output  
T: Preset Time, TON: Preset ON Time, TOFF: Preset OFF Time

### DELAYED PULSE (REMOTE TRIG.) [28]

The timing period (TOFF) will start when input signal is applied with the supply connected. After preset time (TOFF) has elapsed the output is switched ON for the per-selected pulse (TON) duration. To reset the timer either input signal needs to be removed or supply has to interrupt. If this action occurs during the pulsed output cycle (TON) then output is switched OFF and the timer will reset.

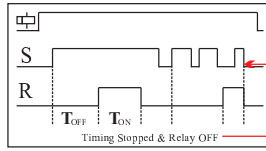

### ON PULSE (CONTROL SWITCH RESETTABLE) / WATCH DOG TYPE [30]

When the supply is connected and signal is applied, output is switched ON and the timing function starts. If signal is removed and applied during the preset timing then timing is restarted and output stays ON. After preset time (TON) has elapsed the output is switched OFF.

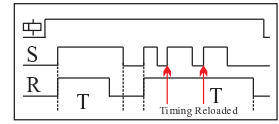

### DELAYED PULSE (CONST. SUPPLY TYPE 1) [29]

Supply to the unit must be continuous. On application of input signal the time period 'TOFF' starts to run. On completion of 'TOFF', the relay output is switched ON immediately and the time period 'TON' starts to run. On completion of 'TON' the output is switched OFF. The input signal has no effect until 'TOFF' + 'TON' have completely expired.

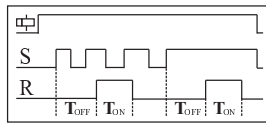

### ON PULSE (SUPPLY RESET)[31]

On application of supply voltage the output is switched ON. The first pulse of input signal starts the preset time period. Receiving pulses during the time period extends it and output stays ON. Receiving no signal pulses during the time period completes it and output is switched OFF. Output stays OFF until supply voltage has been interrupted.

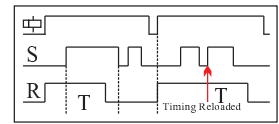

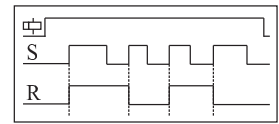

### LEADING EDGE BI-STABLE OR STEP RELAY [32]

After every signal, the output contact changes their states, alternately switching from open to close and vice versa.



## TERMINAL TORQUE & CAPACITY

	0.50 N.m (4.5 Lb.in)
Ø 3.5 mm	
	1 x 1.5 mm <sup>2</sup> Solid/Stranded Wire
AWG	1 x 26 to 14

## CONNECTION DIAGRAM

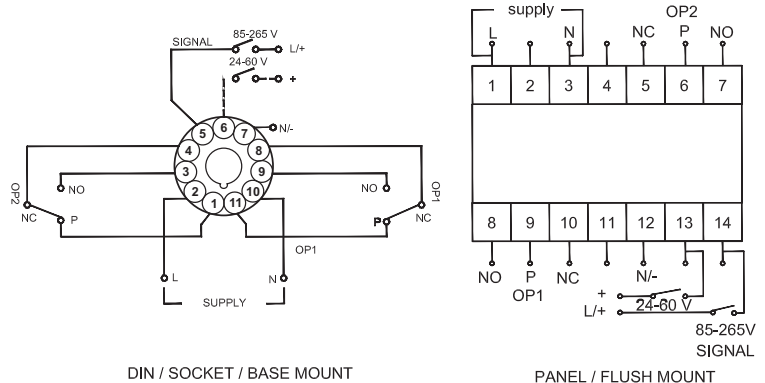

DIN / SOCKET / BASE MOUNT

PANEL / FLUSH MOUNT

## MOUNTING DIMENSIONS (mm)

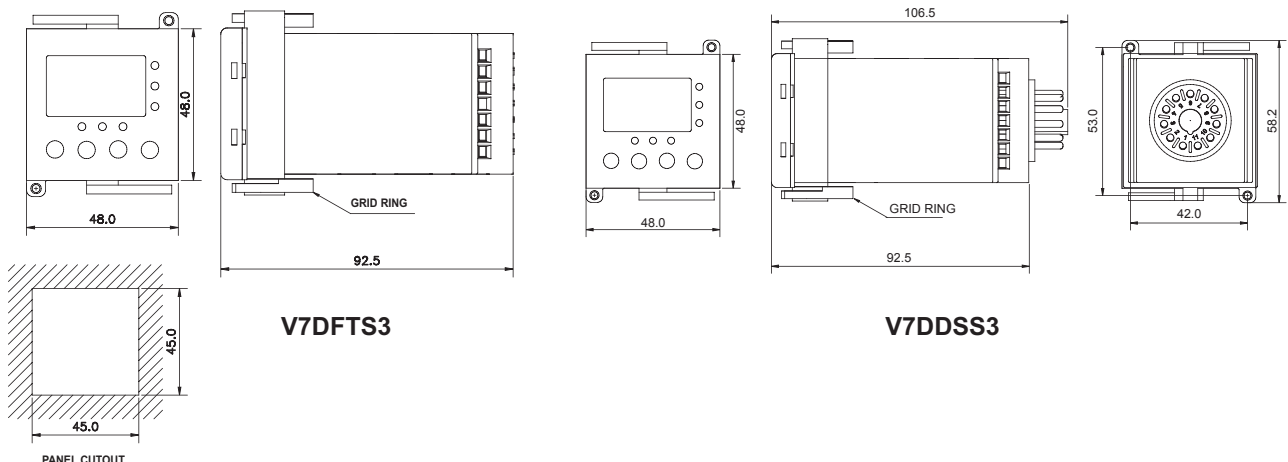



# Electronic Timer - Series Micon® 175

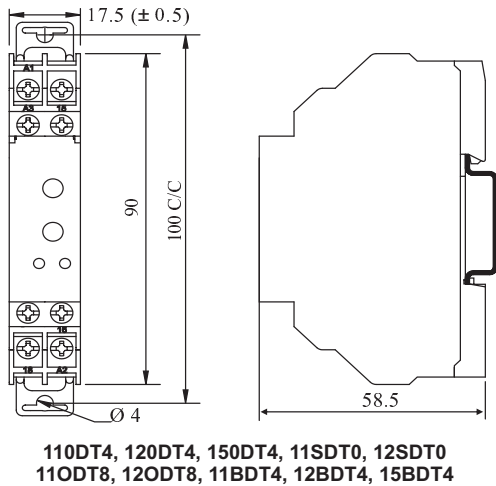
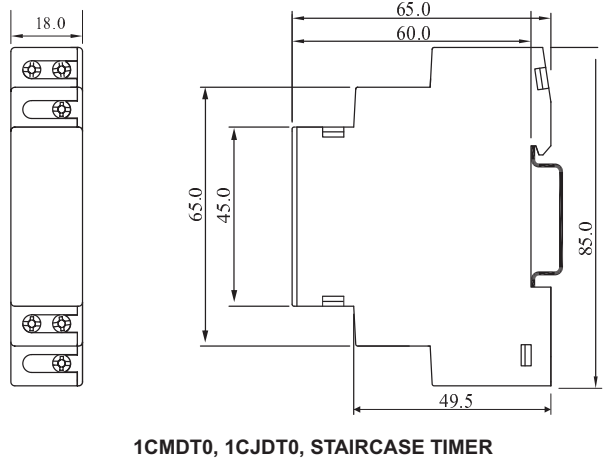
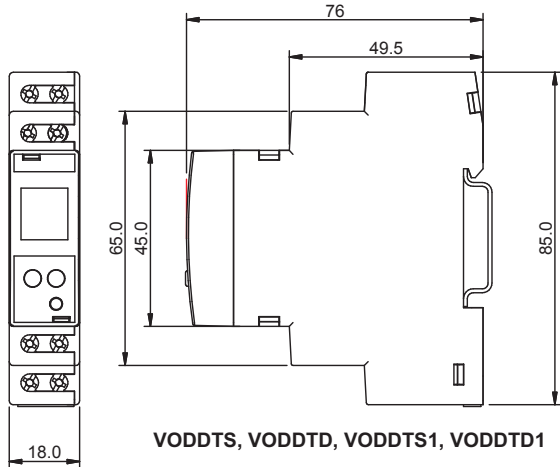

## MOUNTING DIMENSIONS (mm)

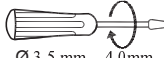



## TERMINAL TORQUE & CAPACITY

 Ø 3.5 mm....4.0mm	0.60 N.m (6 Lb.in)
	1 x 4.0 mm <sup>2</sup> Solid/Stranded Wire
AWG	1 x 20 to 10

**VODDTS, VODDTD, VODDTS1, VODDTD1**

 Ø 3.5 mm....4.0mm	0.60 N.m (6 Lb.in)
	1 x 4.0 mm <sup>2</sup> Solid/Stranded Wire
AWG	1 x 20 to 10

**1CMDT0, 1CJDT0, STAIRCASE TIMER**

 Ø 3.5 mm....5.0mm	0.80 N.m (7.1 Lb.in)
	2 x 2.5 mm <sup>2</sup> Solid/Stranded Wire
AWG	2 x 20 to 14

**110DT4, 120DT4, 150DT4, 11SDT0, 12SDT0, 11ODT8, 12ODT8, 11BDT4, 12BDT4, 15BDT4**

## CONNECTION DIAGRAM

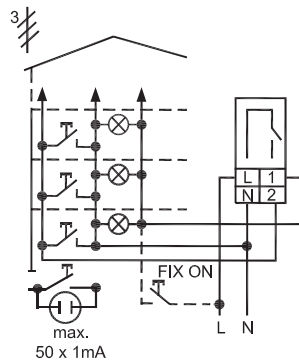
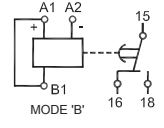
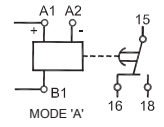
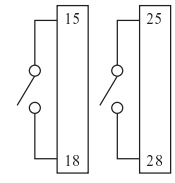
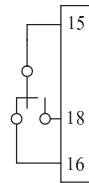
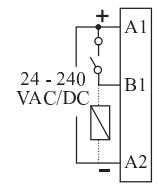
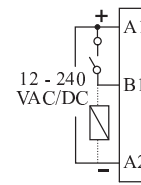
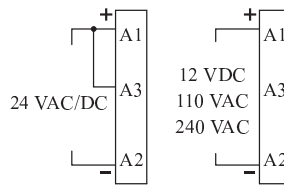

max. 50 x 1mA

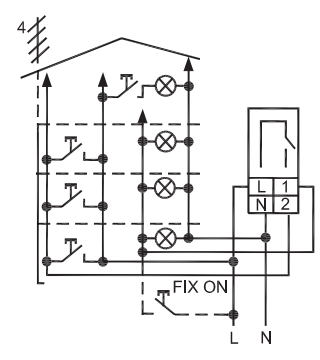

**STAIRCASE TIMER**