

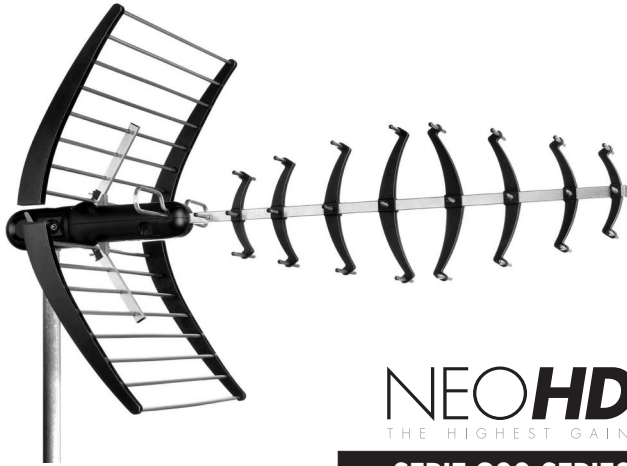

CÓMO MONTAR LA ANTENA NEO-095
 HOW TO MOUNT THE ANTENNA NEO-095
 COMMENT MONTER L'ANTENNE NEO-095

ANTENAS TV BANDA UHF
 TV ANTENNAS UHF BAND
 ANTENNES TV BANDE UHF



NEOHD
 THE HIGHEST GAIN
SERIE 900 SERIES

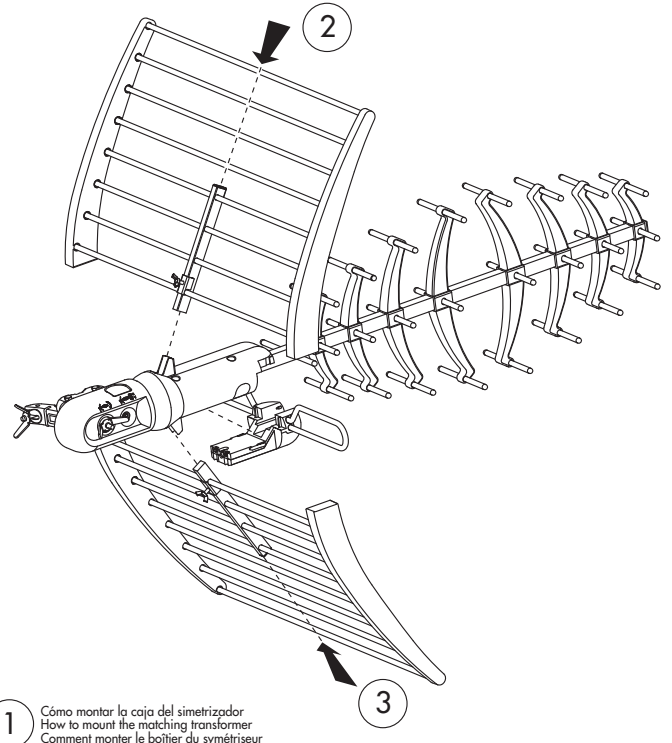

1 Cómo montar la caja del simetrizador
 How to mount the matching transformer
 Comment monter le boîtier du symétriseur

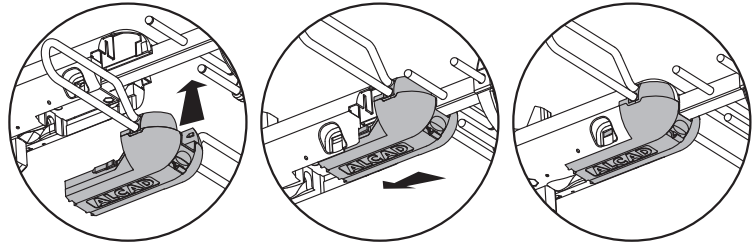

CÓMO FIJAR LA ANTENA AL MÁSTIL
 HOW TO ATTACH THE ANTENNA TO THE MAST
 COMMENT FIXER L'ANTENNE AU MÂT

CÓMO CONECTAR EL CABLE COAXIAL EN LA CAJA DEL SIMETRIZADOR
 HOW TO CONNECT THE COAXIAL CABLE TO THE MATCHING TRANSFORMER
 COMMENT RELIER LE CÂBLE COAXIAL DANS LE BOÎTIER DU SYMÉTRISEUR

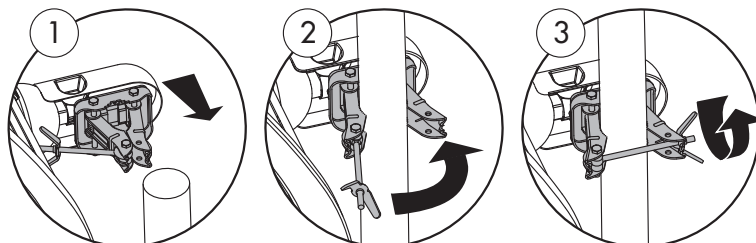
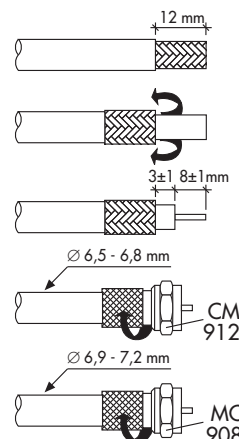
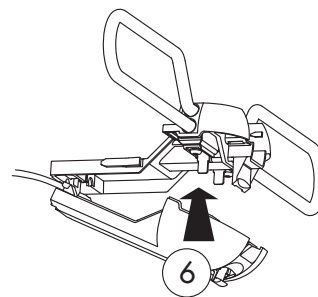
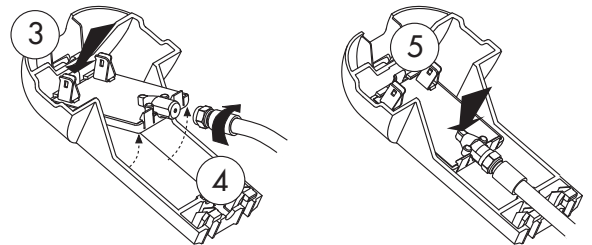
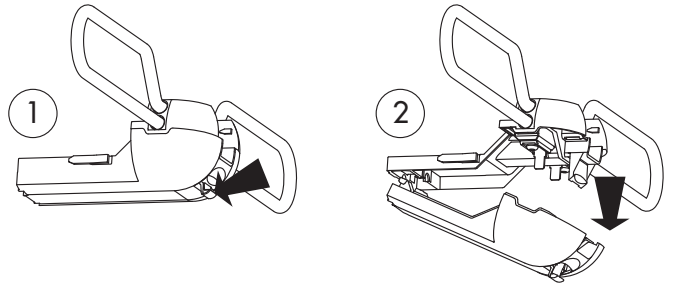
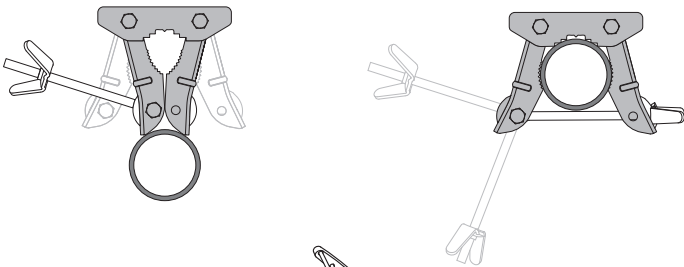

MONTAJE DE LA POLARIDAD HORIZONTAL O VERTICAL
MOUNTING IN EITHER HORIZONTAL OR VERTICAL POLARITY
MONTAGE EN HORIZONTAL OU VERTICAL

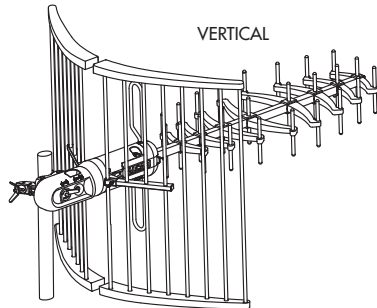
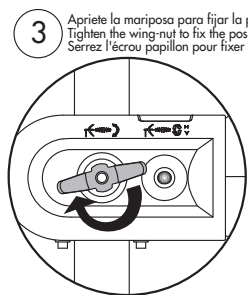
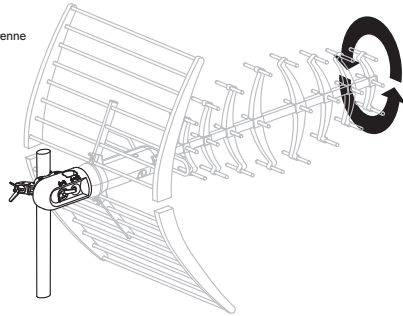
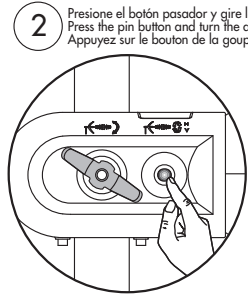
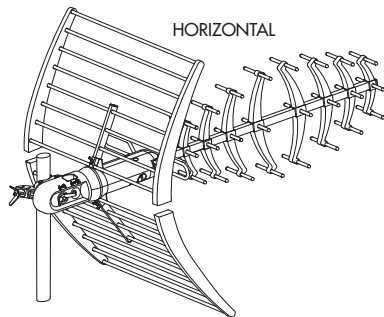
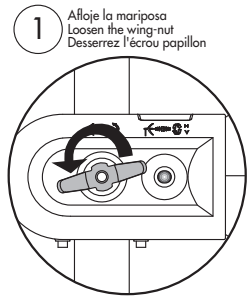

AJUSTE DEL ÁNGULO DE ELEVACIÓN
ELEVATION ANGLE ADJUSTMENT
RÉGLAGE DE L'ANGLE D'ÉLEVATION

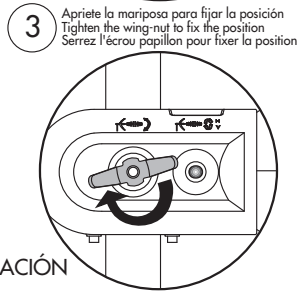
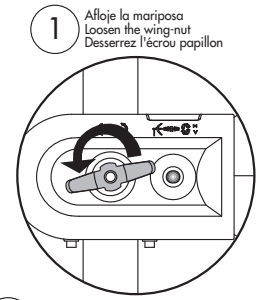
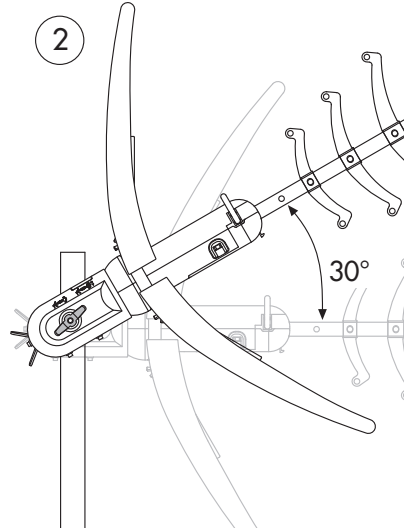

CURVA DE GANANCIA Y DIAGRAMAS DE RADIACIÓN
GAIN AND RADIATION GRAPHICS
COURBE DU GAIN ET DIAGRAMME DE RAYONNEMENT

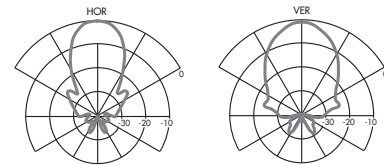
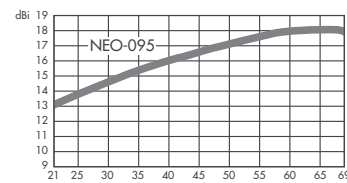

CÓDIGO-CODE-CODE		9000195
MODELO-MODEL-MODELE		NEO-095
Rango de frecuencias Frequency range Gamme de fréquences	MHz	470 - 862
Canales Channels Canaux		21-69
Ganancia Gain Gain	dBi	18
Relación delante/detrás Front/back ratio Rapport avant/arrière	dB	32
Impedancia Impedance Impédance	Ω	75
Pérdidas de retorno Return loss Pertes de retour	dB	≥ 10
Polarización Polarity Polarisation		HOR / VER
Ángulo de apertura Beam width Angle d'ouverture	° H	30
	° V	28
Longitud Length Longueur	mm	1160
Resistencia al viento Wind loading Résistance au vent	N H	130
	V V	100
Índice de protección Protection index Indice de protection		IP 55

Todas las antenas incorporan simetizador.
 All antennas supplied with matching transformer.
 Toutes les antennes ont un symétriseur.



DECLARATION OF CONFORMITY

according to EN ISO/IEC 17050-1:2004

Manufacturer's Name: ALCAD, S.L.
Manufacturer's Address: Pol. Ind. Arreche-Ugalde, 1
 Apdo. 455, 20305 IRÚN (Guipúzcoa), SPAIN

declares that the product
Model Number(s): NEO-095
Product Description: TV ANTENNAS UHF BAND
Product Option(s): INCLUDING ALL OPTIONS
is in conformity with:
 Safety: EN 50083-1:1993

The product herewith complies with the requirements of the Low Voltage Directive 2006/95/EC and the EMC Directive 2004/108/EC.

Supplementary Information: To comply with these directives, do not use the products without covers and operate the system as specified.



Irún (SPAIN), 17 Oct 2009

Francisco Navarro
 General Manager

Especificaciones sujetas a modificación sin previo aviso
 Specifications subject to modifications without prior notice
 Les spécifications sont soumises à de possible modifications sans avis préalable



ALCAD, S.L.
 Tel. 943 63 96 60
 Fax 943 63 92 66
 Int. Tel. +34 - 943 63 96 60
 info@alcad.net
 Apdo. 455 - Pol. Ind. Arreche-Ugalde, 1
 20305 IRUN - Spain
www.alcad.net

FRANCE - Hendaye
 Tel. 00 34 - 943 63 96 60
 GERMANY - Munich
 Tel. 089 55 26 480
 CZECH REPUBLIC - Ostrovačice
 Tel. 546 427 059
 UNITED ARAB EMIRATES - Dubai
 Tel. 971 4 887 19 50

